

**AVEL**®

**KITCHEN  
CABINET TV**



## AVAILABLE FOR PURCHASE WORLDWIDE

The production of AVEL integrated Cabinet Door TVs for the kitchen began in 2013, and now our company has become the world leader in this market.

Thanks to our honest and open business conduct, as well as the high quality of the product, we have established an extensive partner network that distributes AVEL products worldwide. The result of our work is more than 11 thousand televisions sold over the years.

We are constantly improving our TVs considering incoming ideas, suggestions and the market trends. This allows us to produce a very special yet a modern product that meets the customer's expectations.



## MANUFACTURED AT OUR OWN PRODUCTION IN CHINA



All AVEL TVs are manufactured on our own assembly lines in China using the most modern components. We carefully test and assemble by hand all our models. With the strict quality control and use of advanced technologies we produce the best products for our customers.

Production capacity was increased twice in 2017 to fulfill the growing demand of our clients. It is the best indication of the positive consumer and marketing feedback and our product demand trend.



## EASY TO INSTALL, CONVENIENT TO USE

AVEL Kitchen TVs are compatible with the most popular lifting systems from Kessebohmer, Blum and Hafele – 3 world's leading cabinet hardware vendors. These strong and reliable mounts can support the weight of the TV and guarantee the durability of the structure. The hinges ensure a soft and smooth ride during opening and closing.

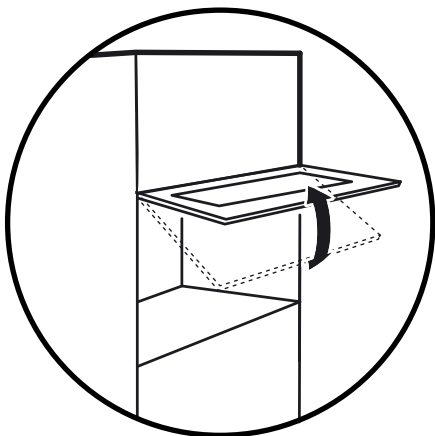

The "Flap" type of lifting mechanism is the standard solution for your kitchen. The TV rises like a kitchen cabinet door, giving you access to the space behind it. Easy installation and familiar design make this mounting option very popular.

The "Slide" type of lifting mechanism is a convenient and safe way to mount the TV. When you open the device, it slides up, freeing access to the shelves. Meanwhile, the screen remains available for viewing. This type of mount may not be suitable for you if your TV is mounted quite high.

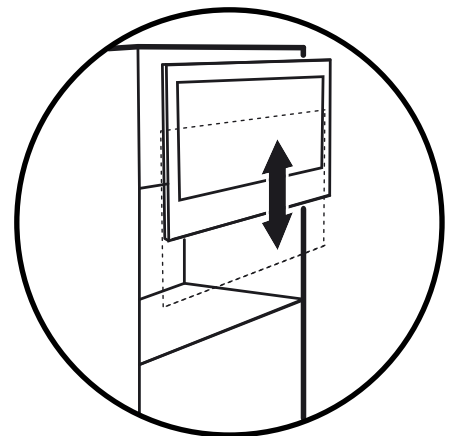

Kessebohmer, Blum and Hafele lift systems are not included in the delivery package.

You can purchase these lifting systems from local distributors worldwide. Information about the compatibility of lifting mechanisms with AVEL TVs is available on our website [www.aviselectronics.com](http://www.aviselectronics.com).



KESSEBÖHMER

HÄFELE

## KEY FEATURES

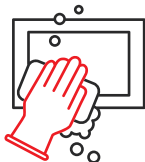
**1**

No special care required; TV front can be washed the same way as a regular glass.

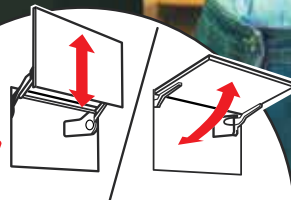
**2**

Easy to mount with the popular lifting systems from Kesseböhmer, Blum and Hafele.

**3**

Heat dissipation design; TV can be safely installed next to any kitchen appliance, even above an oven or stove.

AVEL built-in TVs are specifically designed for the real kitchen environment. Their main feature therefore is the front panel protection from moisture, which guarantees the TV safety when water or steam gets on it during cooking. The package includes a waterproof remote control that can be used even if your hands are wet and simply rinsed under a tap.

Another advantage of AVEL kitchen TVs is tempered glass that protects the front panel. It is durable and resistant to temperature extremes that are possible in the kitchen, and ensures complete safety of the device operation.

All 2022 AVEL kitchen TVs run on Android. This turns them into modern Smart TV multimedia devices that will give you pleasant moments of entertainment.

## OUR TV'S IN THE INTERIOR OF KITCHENS



## AVS240WS

DIMENSIONS: 382x594 mm



Black

White

23,8"

Diagonal



Wi-Fi

Wi-Fi

Full HD  
1080

IPS matrix

DVB T2

Digital tuner



Tempered glass



Smart «Android TV»

This kitchen TV is a compact model that has the same installation dimension standard as a built-in microwave oven.

## AVS240KS

DIMENSIONS: 455x594 mm



23,8"

Diagonal



Wi-Fi

Wi-Fi



Vibration speakers

Full HD  
1080

IPS matrix

DVB T2

Digital tuner



Smart «Android TV»



Tempered glass



Black

White

Mirror

## AVS245K

DIMENSIONS: 455x594 mm



Diagonal



Wi-Fi



IPS matrix



Touch screen



Vibration speakers



Android

The AVS245K touch panel is installed in kitchen furniture and fits perfectly into a 600 mm wide cabinet. The device works on Android, representing a large tablet for the kitchen. You can easily install additional applications from the Google Play Market, thereby expanding the standard functionality of the Android AVS245K panel.

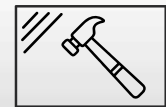

Tempered glass

## AVS320KS

DIMENSIONS: 455x894 mm

## AVS325KS

DIMENSIONS: 514x756 mm



This kitchen TV is installed into 900 mm extra wide cabinets.

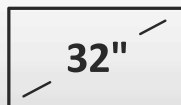

Diagonal



Vibration speakers



This kitchen TV is installed into 762 mm (30") US standard cabinets.



Wi-Fi



Smart «Android TV»

DVB T2

Digital tuner



IPS matrix



Tempered glass

# TECHNICAL PARAMETERS



Cabinet Door TV for Kitchen	AVS245K	AVS240WS	AVS240KS	AVS320KS	AVS325KS
Screen	23,8" (61 cm) LED LCD			32" (81 cm) LED LCD	
Resolution	1920x1080				
Contrast ratio	1 000:1 (typ.)			1 200:1 (typ.)	
Color depth	16.7M				
Brightness	250 cd/m2			350 cd/m2	
Viewing angle (goriz./vert.)	178°/178°				
Bluetooth	Available				
Product size (WxHxD)	594 x 455 x 50 mm	594 x 382 x 52 mm	594 x 455 x 50 mm	894 x 455 x 54 mm	756 x 514 x 56 mm
Product net weight	10 kg	8,5 kg	9,5 kg	14,7 kg	13,5 kg
Mains Power	AC 100-240V (DC 12V/4,25A adaptor)		AC 90-264V		
Power consumption	19 W	24 W		39 W	
Processor	Rk3288 Cortex-A17 up to 1.8 GHz	RTD2841PFG-GR ARM Cortex-A55 up to 1.1GHz (Quad core)		RK3288 Cortex-A17 up to 1.8 GHz	
Touch screen	Capacitive multi-touch			—	
Operating system	Android 9.0		Android TV 9.0		
Media Player	Support for video, photo, and audio files from external USB and HDD				
RAM	DDR3 2G		DDR3 1.5G		
Internal memory	16G		8G		
Analog TV tuner	—		Video: PAL/SECAM/NTSC Audio: B/G, D/K, I,		
Digital TV tuner	—		DVB-T / DVB-T2 / DVB-C / S2 / S2X (H.264/H.265, Dolby)		
Port and connectors	Wi-Fi, SD, DC In (12V), USB, Earphone, RJ45, OTG	Wi-Fi, Composite In (AV, 3.5 mm Mini Jack), Optical fiber (Digital Audio Out), IR pass through, TV (75 Ohm, DVB-T/T2/C/Analogue), TV (S2/S2X), 3xHDMI, VGA + PC Audio (Mini Jack), 2xUSB, Earphone, Component In (Y/Pb/Pr, 3.5 mm Mini Jack), CI slot (CI +), RJ45			
Speakers	2 internal vibrodynamics 6 W	2 internal dinamycs 5 W	2 internal vibrodynamics 8 W		
Protection class	IP65 (waterproof front panel)				
Remote control	Air mouse	Waterproof against water jets Ip66, Air mouse			
Lift systems compatibility					
Blum Aventos	HK top 29; HL 27/38	HK top 27; HL 27/35	HK top 29; HL 27/38	HK top 29; HL 29/35	HK top 29; HL 29/38
Kessebohmer	FREEflap forte-F FREEslide Q3us	FREEflap forte-E FREEslide Q3us	FREEflap forte-F FREEslide Q3us	FREEflap forte-G FREEslide Q4us	FREEflap forte-G FREEslide Q4us
Hafele	Free Flap 3.15 F Free up Q3us	Free Flap 3.15 E Free up Q3us	Free Flap 3.15 F Free up Q3us	Free Flap 3.15 G Free up Q4us	Free Flap 3.15 G Free up Q4us

TV  
DIMENSIONS, MM

AVS240WS 382\*594

AVS245K 455\*594  
AVS240KS

AVS320KS 455\*894  
AVS325KS 514\*756



## OVERALL DIMENSIONS AND INSTALLATION

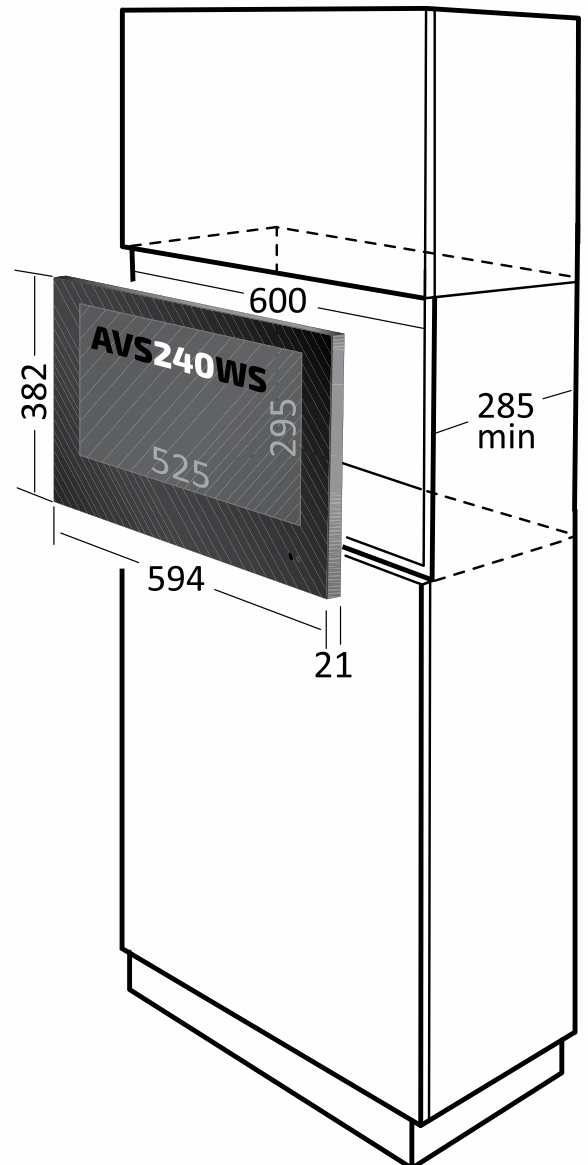
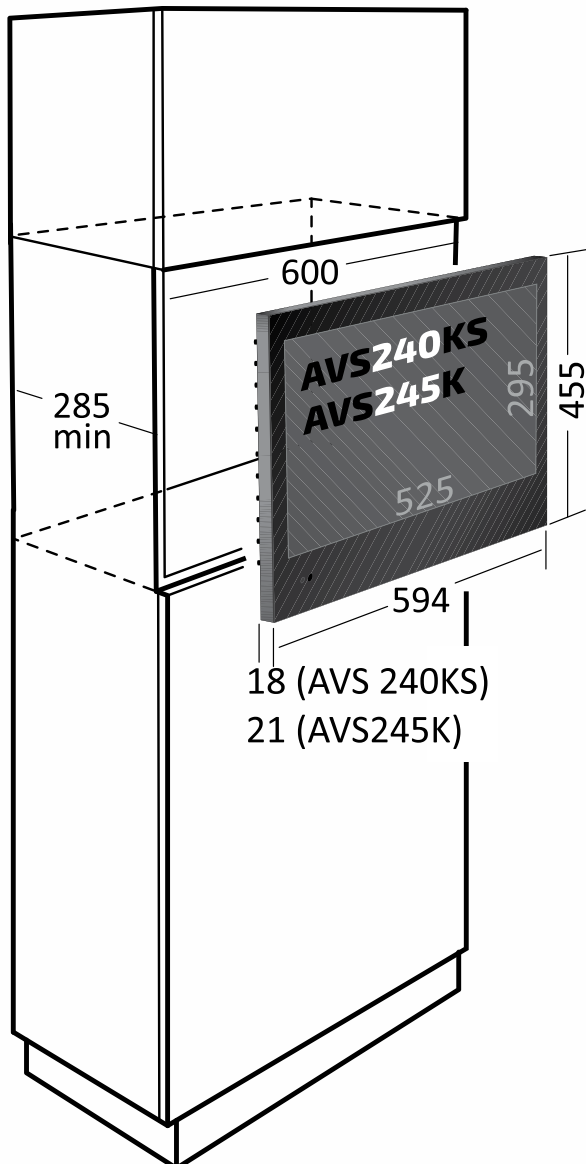

These TV models are designed for installation in standard 600 mm wide kitchen cabinets.

## OVERALL DIMENSIONS AND INSTALLATION

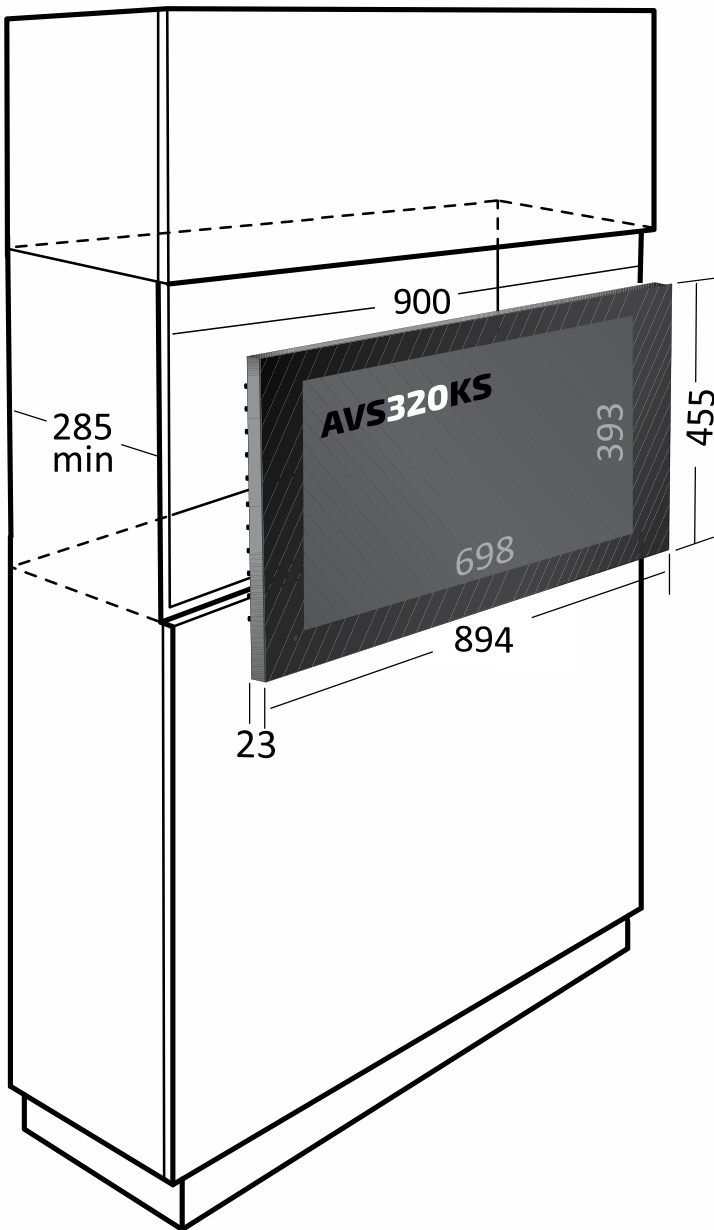

AVS320KS is installed into 900 mm extra wide cabinets.

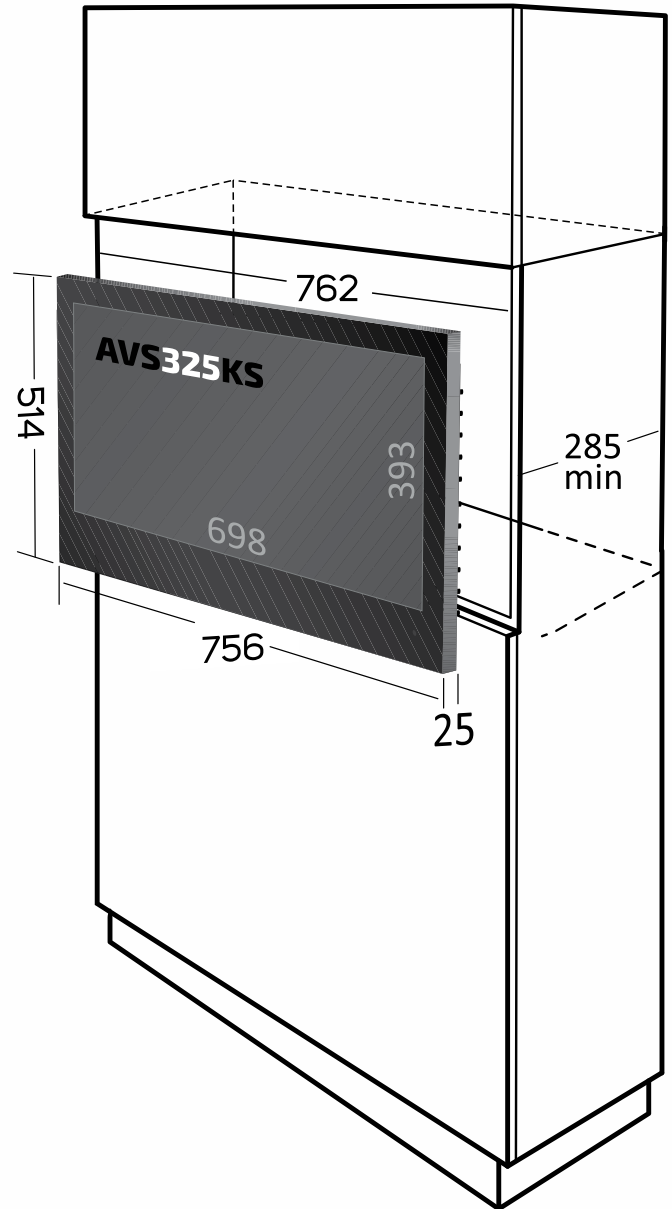

AVS325KS is installed into 762 mm (30") US standard cabinets.

## TV INSTALLATION STEPS



1  
Mark and drill holes on the sides of the cabinet in accordance with the Installation Instruction provided.



2  
Install the lifting mechanisms.



3  
Fix the counterparts of the lifting mechanism on the rear panel of the TV in accordance with the marking.



4  
Install the TV to the lifting mechanism, adjust the TV position and the spring tension of the lifting mechanism.

## NOTES

---

---

---

---

---

---

---

---

---

---

---

---

---

---

---

---

---

---

---

---

---

---

---

---

---

---



[www.avelinnovations.com.au](http://www.avelinnovations.com.au)

**Australian Distributor**

2 Catherine Street, Coburg North  
Victoria Australia 3058

Mobile: 0423 494 545

Email: [info@avelinnovations.com.au](mailto:info@avelinnovations.com.au)